



User's Guide

NHD-16032AZ-FL-YBW

LCM

(Liquid Crystal Display Graphic Module)

RoHS Compliant

NHD-	Newhaven Display
16032-	160 x 32 pixels
AZ-	Version Line
F-	Transflective
L-	Yellow/Green LED B/L
Y-	STN- Yellow/Green
B-	6:00 View
W-	Wide Temperature (-20 ~ +70c)

For product support, contact

Newhaven Display International, LLC
2511 Technology Drive, #101
Elgin, IL 60124
Tel: (847) 844-8795 Fax: (847) 844-8796

February 29, 2008

DOCUMENT REVISION HISTORY

Version	DATE	DESCRIPTION	CHANGED BY
00	June-7-07	First issue	

CONTENTS

Item	Page
Functions & Features	3
Mechanical specifications	3
Dimensional Outline	4
Absolute maximum ratings	5
Block diagram	5
Pin description	5
Optical characteristics	6
Electrical characteristics	6
Timing Characteristics	6-7
Instruction description	8-13
Quality Specifications	14--21

1. Features

1. 160x32 dots
2. Built-in controller (ST7920)
3. +5V power supply
4. 1/32 duty cycle;1/9bias
5. BKL to be driven pin15, pin16

LCD type	<input type="checkbox"/> FSTN positive		<input type="checkbox"/> FSTN Negative	
	<input checked="" type="checkbox"/> STN Yellow Green	<input type="checkbox"/> STN Gray		<input type="checkbox"/> STN-Blue
View direction	<input checked="" type="checkbox"/> 6 O'clock		<input type="checkbox"/> 12 O'clock	
Rear Polarizer	<input type="checkbox"/> Reflective		<input checked="" type="checkbox"/> Transflective	<input type="checkbox"/> Transmissive
Backlight Type	<input checked="" type="checkbox"/> LED	<input type="checkbox"/> EL		<input type="checkbox"/> Internal Power
		<input type="checkbox"/> CCFL	<input checked="" type="checkbox"/> External Power	<input type="checkbox"/> 5.0V input
Backlight Color	<input type="checkbox"/> White	<input type="checkbox"/> Amber	<input type="checkbox"/> Blue-Green	<input checked="" type="checkbox"/> Yellow-Green
Temperature Range	<input type="checkbox"/> Normal		<input checked="" type="checkbox"/> Wide	<input type="checkbox"/> Super Wide
DC to DC circuit	<input checked="" type="checkbox"/> Build-in		<input type="checkbox"/> Not Build-in	
EI Driver IC	<input type="checkbox"/> Build-in		<input checked="" type="checkbox"/> Not Build-in	
Touch screen	<input type="checkbox"/> With		<input checked="" type="checkbox"/> Without	
Font type	<input type="checkbox"/> English-Jap	<input type="checkbox"/> English-Eur	<input type="checkbox"/> English-Russian	<input checked="" type="checkbox"/> other
	anese	open		

2. MECHANICAL SPECIFICATIONS

Module size	114.0mm(L)*40.0mm(W)* Max13.5(H)mm
Viewing area	92.0mm(L)*22.0mm(W)
Dots size	0.49mm(L)*0.49mm(W)
Dots pitch	0.54mm(L)*0.54mm(W)
Weight	Approx.

3. Outline dimension

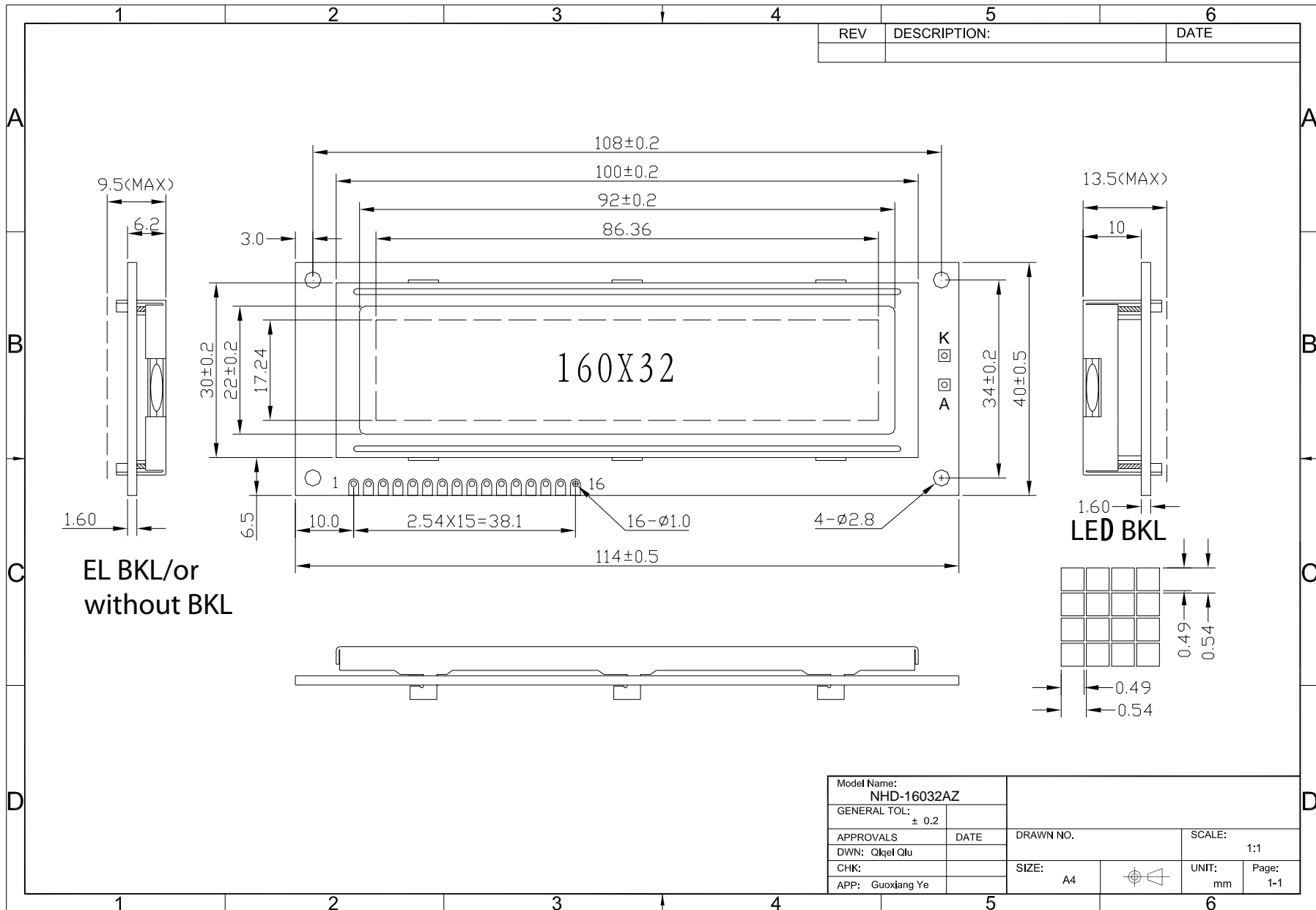

4. Absolute maximum ratings

Item	Symbol	Standard			Unit
Power voltage	$V_{DD}-V_{SS}$	0	-	7.0	V
Input voltage	V_{IN}	V_{SS}	-	V_{DD}	
Operating temperature range	V_{OP}	-20	-	+70	
Storage temperature range	V_{ST}	-30	-	+80	

5 . Block diagram

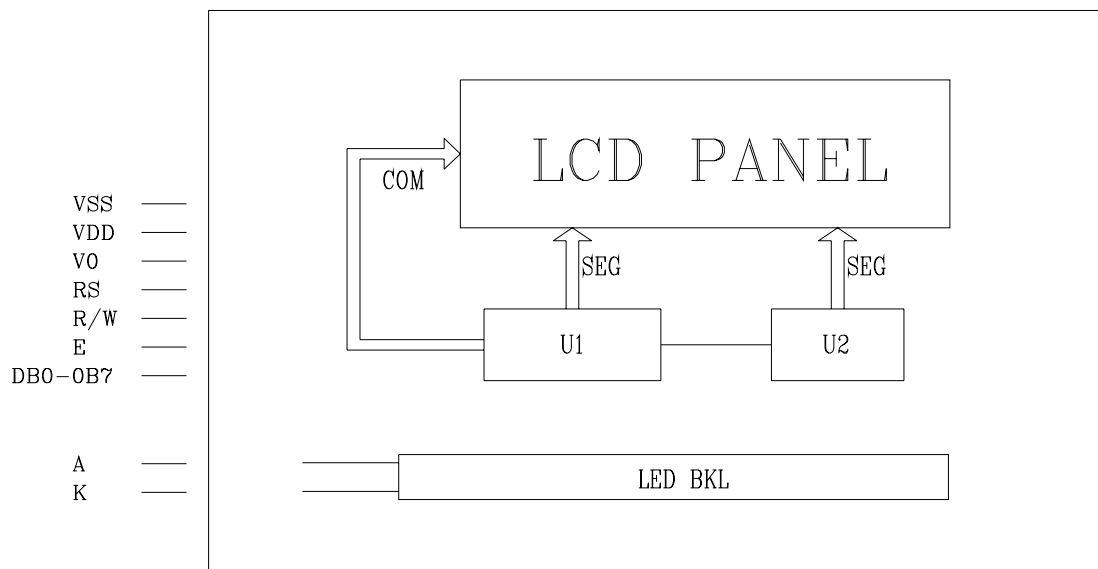

6. Interface pin description

Pin no.	Symbol	External connection	Function
1	V_{SS}	Power supply	Signal ground for LCM (GND)
2	V_{DD}	Power supply	Power supply for logic (+5V) for LCM
3	V_0	Power supply	Contrast adjust
4	R/S	MCU	Register select signal
5	R/W	MCU	Read/write select signal
6	E	MCU	Operation (data read/write) enable signal
7-14	DB0-DB7	MCU	8-bit, tri-state, bi-directional I/O bus. Normally, connected to the data bus of an 8-/16-bit standard microcomputer.
15	LED+	Power supply	Power supply for BKL
16	LED-		Power supply for BKL

7. Optical characteristics

STN type display module ($T_a=25$, $V_{DD}=5.0V$)

Item	Symbol	Condition	Min.	Typ.	Max.	Unit
Viewing angle		C_r 3	10	-	60	deg
			-45	-	45	
Contrast ratio	C_r		-	5	-	-
Response time (rise)	T_r	-	-	100	150	ms
Response time (fall)	T_r	-	-	150	200	

8. Electrical characteristics

DC characteristics

Parameter	Symbol	Conditions	Min.	Typ.	Max.	Unit
Supply voltage for LCD	V_0-V_{SS}	$T_a=25$	-	5.0	-	V
Input voltage	V_{DD}		-	3.3	-	
Supply current	I_{DD}	$T_a=25$, $V_{DD}=5.0V$	-	2	3.0	mA
Input leakage current	I_{LKG}		-	-	1.0	μA
"H" level input voltage	V_{IH}		2.2	-	V_{DD}	V
"L" level input voltage	V_{IL}	Twice initial value or less	0	-	0.6	
"H" level output voltage	V_{OH}	LOH=-0.25mA	2.4	-	-	
"L" level output voltage	V_{OL}	LOH=1.6mA	-	-	0.4	
Backlight supply voltage	V_F	Yellow-Green	-	5.0	-	
Backlight supply current	I_F	$V_F=5.0V$	-	120	-	mA

9. Timing Characteristics

AC CHARACTERISTICS($V_{DD}=5V, T_a=25$)

SYMBOL	CHARACTERISTICS	TEST CONDITION	MIN.	TYP.	MAX.	UNIT
FOSC	OSC FREQUENCY	$R_F=39K$	480	540	600	KHZ

WRITE TIMING

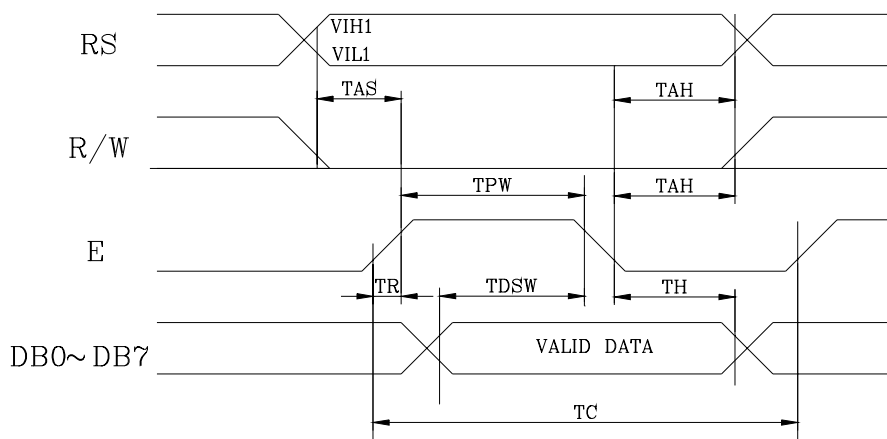

for write mode (writing data from mpu to st7920)

parameter	symbol	mesure time	unit
SYSTEM CYCLE TIME	TC	13,000	NS
ADDRESS SETUP TIME	tas	1,500	NS
ADDRESS HOLD TIME	TAH	1,500	NS
DATA SETUP TIME	TDSW	1,000	NS
DATA HOLD TIME	TH	20	NS
ENABLE PULSEWIDTH	TPW	1,500	NS
ENABLE RISE/FALL TIME	TR,TF	25	NS

READ TIMING

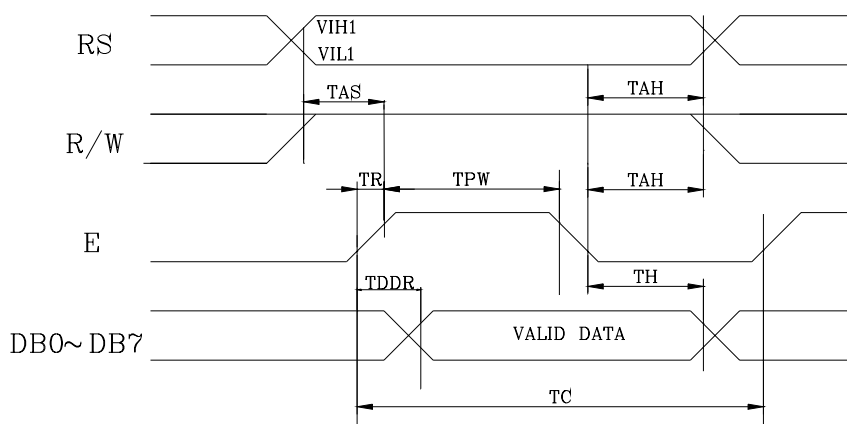

FOR READ MODE(READING DATA FORM ST7920 TO MPU)

parameter	symbol	mesure time	unit
SYSTEM CYCLE TIME	TC	13,000	NS
ADDRESS SETUP TIME	tas	1,500	NS
ADDRESS HOLD TIME	TAH	1,500	NS
DATA SETUP TIME	TDDR	1,000	NS
DATA HOLD TIME	TH	20	NS
ENABLE PULSEWIDTH	TPW	1,500	NS
ENABLE RISE/FALL TIME	TR,TF	25	NS

CHARACTER GENERATOR ROM (CGROM)

THE CHARACTER GENERATOR ROM GENERATES 16 X 16 DOT OR 16 X 8 DOT CHARACTER PATTERNS FROM TWO 8-BIT CHARACTER CODES. USER-DEFINED CHARACTER PATTERNS ARE ALSO AVAILABLE BY MASK-PROGRAMMED ROM.

CHARACTER GENERATOR RAM (CGRAM)

IN THE CHARACTER GENERATOR RAM, THE USER CAN REWRITE CHARACTER PATTERNS BY PROGRAM. FOR 16 X 16 DOTS, FOUR CHARACTER PATTERNS CAN BE WRITTEN.

SEE TABLE 1 FOR THE RELATIONSHIP BETWEEN CGRAM ADDRESSES AND DATA AND DISPLAY PATTERNS. AREAS THEY ARE NOT USED FOR DISPLAY CAN BE USED AS GENERAL DATA RAM.

TIMING GENERATION CIRCUIT

THE TIMING GENERATION CIRCUIT GENERATES TIMING SIGNALS FOR THE OPERATION OF INTERNAL CIRCUITS SUCH AS DDRAM, CGROM AND CGRAM. RAM READ TIMING FOR DISPLAY AND INTERNAL OPERATION TIMING BY MPUACCESS ARE GENERATED SEPARATELY TO AVOID INTERFERING WITH EACH OTHER. THEREFORE, WHEN WRITING DATA TODDRAM, FOR EXAMPLE, THERE WILL BE NO UNDESIRABLE INTERFERENCE, SUCH AS FLICKERING, IN AREAS OTHER THAN THE DISPLAY AREA.

LCD DRIVER CIRCUIT

LCD DRIVER CIRCUIT HAS 33 COMMON AND 64 SEGMENT SIGNALS FOR LCD DRIVING. DATA FROM CGRAM/CGROM IS TRANSFERRED TO 64 BIT SEGMENT LATCH SERIALY, AND THEN IT IS STORED TO 64 BIT SHIFT LATCH. WHEN EACH COMMON IS SELECTED BY 33 BIT COMMON REGISTER, SEGMENT DATA ALSO OUTPUT THROUGH SEGMENT DRIVER FROM 64 BIT SEGMENT LATCH.

CURSOR/BLINK CONTROL CIRCUIT

IT CAN GENERATE THE CURSOR OR BLINK IN THE CURSOR/BLINK CONTROL CIRCUIT. THE CURSOR OR THE BLINK APPEARS IN THE DIGIT AT THE DISPLAY DATA RAM ADDRESS SET IN THE ADDRESS COUNTER.

CHARACTER CODE DDRAM DATA					CGRAM ADDRESS						CGRAM DATA HIGH BYTE								CGRAM DATA LOW BYTE														
B15~B4	B3	B2	B1	B0	B5	B4	B3	B2	B1	B0	D15	D14	D13	D12	D11	D10	D9	D8	D7	D6	D5	D4	D3	D2	D1	D0							
0	X	0	0	X	0	0	0	0	0	0	0	0	0	0	0	0	0	0	1	0	0	0	0	0	0	0	0						
							0	0	0	1	0	0	0	0	0	0	0	0	0	0	0	0	0	1	1	0	0	0	0	0	0	0	
							0	0	1	0	0	0	0	0	1	1	1	1	1	1	1	1	1	1	1	1	1	1	1	1	0	0	0
							0	0	1	1	0	0	0	0	0	0	0	0	0	0	0	0	0	0	0	0	0	0	0	0	0	0	0
							0	1	0	0	0	0	0	0	0	0	0	0	0	0	0	0	0	0	1	1	1	0	0	0	0	0	0
							0	1	0	1	0	0	0	0	0	0	0	0	0	0	0	0	0	0	1	0	0	1	0	0	0	0	0
							0	1	1	0	0	0	0	0	0	0	0	0	0	0	0	0	0	0	1	1	1	0	0	0	0	0	0
							0	1	1	1	0	0	0	0	0	0	0	0	0	0	0	0	0	0	0	0	0	0	0	0	0	0	0
							1	0	0	0	0	0	0	0	1	1	1	1	1	1	1	1	1	1	1	1	1	1	1	1	0	0	0
							1	0	0	1	0	0	0	0	1	0	0	0	0	0	0	0	0	0	0	0	0	0	0	0	1	0	0
							1	0	1	0	0	0	0	0	1	0	0	1	1	1	1	1	1	1	1	1	1	0	0	1	0	0	0
							1	0	1	1	0	0	0	0	1	0	0	1	0	0	1	0	0	0	0	1	0	0	1	0	0	0	0
							1	1	0	0	0	0	0	0	1	0	0	1	0	0	1	1	1	1	1	1	1	0	0	1	0	0	0
							1	1	0	1	0	0	0	0	1	0	0	0	0	0	0	0	0	0	0	0	0	0	0	1	0	0	0
							1	1	1	0	0	0	0	0	1	0	0	0	0	0	0	0	0	0	0	0	0	0	0	1	0	0	0
							1	1	1	1	0	0	0	0	1	0	0	0	0	0	0	0	0	0	0	0	0	0	0	1	0	0	0
1	1	1	1	1	0	0	0	0	0	0	0	0	0	0	0	0	0	0	0	0	0	0	0	0	0	0							
0 t	X	0	1	X	0	1	0	0	0	0	0	0	0	0	0	0	0	1	0	0	0	0	0	0	0	0							
							0	0	0	1	0	0	0	0	0	0	0	0	0	0	0	0	1	1	0	0	0	0	0	0	0		
							0	0	1	0	0	0	0	0	1	1	1	1	1	1	1	1	1	1	1	1	1	1	1	0	0	0	
							0	0	1	1	0	0	0	0	0	0	0	0	0	0	0	0	0	0	0	0	0	0	0	0	0	0	
							0	1	0	0	0	0	0	0	0	0	0	0	0	0	0	0	0	1	1	1	0	0	0	0	0	0	
							0	1	0	1	0	0	0	0	0	0	0	0	0	0	0	0	0	1	0	0	1	0	0	0	0	0	
							0	1	1	0	0	0	0	0	0	0	0	0	0	0	0	0	0	1	1	1	0	0	0	0	0	0	
							0	1	1	1	0	0	0	0	0	0	0	0	0	0	0	0	0	0	0	0	0	0	0	0	0	0	
							1	0	0	0	0	0	0	0	1	1	1	1	1	1	1	1	1	1	1	1	1	1	1	0	0	0	
							1	0	1	0	0	0	0	0	1	0	0	1	1	1	1	1	1	1	1	1	0	0	1	0	0	0	
							1	0	1	1	0	0	0	0	1	0	0	1	0	0	1	0	0	0	0	1	0	0	1	0	0	0	
							1	1	0	0	0	0	0	0	1	0	0	1	1	1	1	1	1	1	1	1	0	0	1	0	0	0	
							1	1	0	1	0	0	0	0	1	0	0	1	0	0	1	1	1	1	1	1	0	0	1	0	0	0	
							1	1	1	0	0	0	0	0	1	0	0	0	0	0	0	0	0	0	0	0	0	0	1	0	0	0	
							1	1	1	1	0	0	0	0	1	0	0	0	0	0	0	0	0	0	0	0	0	0	0	0	0	0	

RELATIONSHIP BETWEEN CGRAM ADDRESSES, CHARACTER CODES(DDRAM) AND CHARACTER PATTERNS (CGRAM DATA)

Notes:

1. CHARACTER CODE BITS 1 TO 2 CORRESPOND TO CGRAM ADDRESS BITS 4 TO 5 (2 BIT: 4 TYPES).
2. CGRAM ADDRESS BITS 0 TO 3 DESIGNATE THE CHARACTER PATTERN LINE POSITION. THE 16TH LINE IS THE CURSOR POSITION AND A LOGICAL OR WITH THE CURSOR FORMS ITS DISPLAY. MAINTAIN THE 16TH LINE DATA, CORRESPONDING TO THE CURSOR DISPLAY POSITION, AS TO AS THE CURSOR DISPLAY. IF THE 16TH LINE DATA IS 1,1 BITS WILL LIGHT UP THE 16TH LINE REGARDLESS OF THE CURSOR PRESENCE.
3. CHARACTER PATTERN ROW POSITIONS CORRESPOND TO CGRAM DATA BITS 0 TO 15 (BIT 15 BEING AT THE LEFT).

*4. AS SHOWN TABLE, CGRAM CHARACTER PATTERNS ARE SELECTED WHEN CHARACTER CODE BITS 4 TO 15 ARE ALL 0 AND BIT 0 AND BIT 3 ARE DON'T CARE (X).

		ICON RAM DATA															
		HIGH BYTE								LOW BYTE							
icon ram address(ac3—ac0)		D15	D14	D13	D12	D11	D10	D9	D8	D7	D6	D5	D4	D3	D2	D1	D0
		0	SEG0	SEG1	SEG2	SEG3	SEG4	SEG5	SEG6	SEG7	SEG8	SEG9	SEG10	SEG11	SEG12	SEG13	SEG14
1	SEG16	SEG17	SEG18	SEG19	SEG20	SEG21	SEG22	SEG23	SEG24	SEG25	SEG26	SEG27	SEG28	SEG29	SEG30	SEG31	
2	SEG32	SEG33	SEG34	SEG35	SEG36	SEG37	SEG38	SEG39	SEG40	SEG41	SEG42	SEG43	SEG44	SEG45	SEG46	SEG47	
3	SEG48	SEG49	SEG50	SEG51	SEG52	SEG53	SEG54	SEG55	SEG56	SEG57	SEG58	SEG59	SEG60	SEG61	SEG62	SEG63	
4	SEG64	SEG65	SEG66	SEG67	SEG68	SEG69	SEG70	SEG71	SEG72	SEG73	SEG74	SEG75	SEG76	SEG77	SEG78	SEG79	
5	SEG80	SEG81	SEG82	SEG83	SEG84	SEG85	SEG86	SEG87	SEG88	SEG89	SEG90	SEG91	SEG92	SEG93	SEG94	SEG95	
6	SEG96	SEG97	SEG98	SEG99	SEG100	SEG101	SEG102	SEG103	SEG104	SEG105	SEG106	SEG107	SEG108	SEG109	SEG110	SEG111	
7	SEG112	SEG113	SEG114	SEG115	SEG116	SEG117	SEG118	SEG119	SEG120	SEG121	SEG122	SEG123	SEG124	SEG125	SEG126	SEG127	
8	SEG128	SEG129	SEG130	SEG131	SEG132	SEG133	SEG134	SEG135	SEG136	SEG137	SEG138	SEG139	SEG140	SEG141	SEG142	SEG143	
9	SEG144	SEG145	SEG146	SEG147	SEG148	SEG149	SEG150	SEG151	SEG152	SEG153	SEG154	SEG155	SEG156	SEG157	SEG158	SEG159	
A	SEG160	SEG161	SEG162	SEG163	SEG164	SEG165	SEG166	SEG167	SEG168	SEG169	SEG170	SEG171	SEG172	SEG173	SEG174	SEG175	
B	SEG176	SEG177	SEG178	SEG179	SEG180	SEG181	SEG182	SEG183	SEG184	SEG185	SEG186	SEG187	SEG188	SEG189	SEG190	SEG191	
C	SEG192	SEG193	SEG194	SEG195	SEG196	SEG197	SEG198	SEG199	SEG200	SEG201	SEG202	SEG203	SEG204	SEG205	SEG206	SEG207	
D	SEG208	SEG209	SEG210	SEG211	SEG212	SEG213	SEG214	SEG215	SEG216	SEG217	SEG218	SEG219	SEG220	SEG221	SEG222	SEG223	
E	SEG224	SEG225	SEG226	SEG227	SEG228	SEG229	SEG230	SEG231	SEG232	SEG233	SEG234	SEG235	SEG236	SEG237	SEG238	SEG239	
F	SEG240	SEG241	SEG242	SEG243	SEG244	SEG245	SEG246	SEG247	SEG248	SEG249	SEG250	SEG251	SEG252	SEG253	SEG254	SEG255	

TABLE 6 RELATIONSHIP BETWEEN ICON RAM ADDRESSES, DATA AND SEGMENT PIN LOCATION BIT MAP.

0 1 2 3 4 5 6 7 8 9 A B C D E F

0	X															
1	▶	◀	‡	!!	¶	§	-	‡	†	↓	→	←	L	++	▼	▲
2		!	"	#	\$	%	&	'	()	*	+	,	-	.	/
3	0	1	2	3	4	5	6	7	8	9	:	:	<	=	>	?
4	@	A	B	C	D	E	F	G	H	I	J	K	L	M	N	O
5	P	Q	R	S	T	U	V	W	X	Y	Z	[\]	^	_
6	'	a	b	c	d	e	f	g	h	i	j	k	l	m	n	o
7	p	q	r	s	t	u	v	w	x	y	z	{	!	}	~	△

10. DISPLAY COMMAND

THE ST7920 WHICH HAVE TWO CATEGORIES OF INSTRUCTIONS THAT:

- INSTRUCTION TABE: (RE=0:ENABLE BASIC INSTRUCTION.)

PARAMETER	RS	RW	DB7	DB6	DB5	DB4	DB3	DB2	DB1	DB0	NOTE	EXECUTION TIME (450KHZ)	
CLEAR DISPLAY	0	0	0	0	0	0	0	0	0	1	WRITE "20H" TO DDRAM AND SET DDRAM ADDRESS TO "00H" FROM AC	2.5MS	
RETURN HOME	0	0	0	0	0	0	0	0	1	X	SET DDRAM ADDRESS TO "00H" FROM AC AND RETURN CURSOR TO ITS ORIGINAL POSITION IF SHIFTED. THE CONTENTS OF DDRAM ARE NOT CHANGE	2.5MS	
ENTRY MODE SET	0	0	0	0	0	0	0	1	ID	S	SETS CURSOR MOVE DIRECTION AND SPECIFIES DISPLAY SHIFT. THESE OPERATIONS ARE PERFORMED DURING DATA WRITE AND READ	60 S	
DISPLAY ON/OFF	0	0	0	0	0	0	1	D	C	B	D=1: ENTIRE DISPLAY ON C=1: CURSOR ON B=1: CURSOR POSITION ON	60 S	
CURSOR OR DISPLAY SHIFT	0	0	0	0	0	1	SC	RL	X	X	SET CURSOR MOVING AND DISPLAY SHIFT CONTROL BIT, AND THE DIRECTION WITHOUT CHANGING DDRAM DATA	60 S	
FUNCTION SET	0	0	0	0	1	DL	N	0	RE	G	X	DL: INTERFACE DATA IS 8/4 BITS N=1 & RE=0: 3 LINE SETTING N=1 & RE=1: 4 LINE SETTING G=1: GRAPHIC DISPLAY ON G=0: GRAPHIC DISPLAY OFF OTHERS: 2 LINE SETTING RE=1: EXTENDED INSTRUCTION SETTING RE=0: NORMAL INSTRUCTION SETTING	60 S
SET CGRAM ADDRESS	0	0	0	1	AC5	AC4	AC3	AC2	AC1	AC0	SET CGRAM ADDRESS IN ADDRESS CORNTER	60 S	
SET DDRAM ADDRESS	0	0	1	AC6	AC5	AC4	AC3	AC2	AC1	AC0	SET DDRAM ADDRESS IN ADDRESS CORNTER	60 S	

READ BUSY FLAG AND ADDRESS	0	1	BF	AC 6	AC 5	AC 4	AC 3	AC 2	AC 1	AC 0	WETHER DURING INTERNAL OPERATION OR NOT CAN BE KNOWN BY READING BF. THE CINTENTS OF ADDRESS COUNTER CAN ALSO BE READ.	0 S
WRITE DATA	1	0	D7	D6	D5	D4	D3	D2	D1	D0	WRITE DATA INTO INTERNAL RAM	60 S
READ DATA	1	1	D7	D6	D5	D4	D3	D2	D1	D0	READ DATA FROM INTERNAL RAM	60 S

● INSTRUCTION TABLE: (RE=1: ENABLE EXTENSION INSTRUCTION.)

PARAMETER	RS	R/W	DB7	DB6	DB5	DB4	DB3	DB2	DB1	DB0	NOTE	EXECUTION TIME (450KHZ)	
STANDBY MODE	0	0	0	0	0	0	0	0	0	1	ENTER STANDBY MODE, ONLY ICON AREAS DISPLAY. STANDBY MODE CAN BE RELEASED BY ANY OTHER INSTRUCTIONS.	60 US	
START ROW ENABLE	0	0	0	0	0	0	0	0	1	SR	SR=1: ALLOW CHANGE START DISPLAY ROW. SR=0: DISABLE START DISPLAY ROW CHANGE.	60US	
REVERSE LINE SELECT	0	0	0	0	0	0	0	1	R1	R0	CHOICE ONE OF 4 LINES WHICH DATA IS REVERSE DISPLAY.	60 S	
SLEEP MODE AND SET GRAM PAGE	0	0	0	0	0	0	1	D	C	B	SL=0: ENTER SLEEP MODE. SL=1: WAKE-UP FROM SLEEP MODE GD: DISPLAY GRAPHIC PAGE 0 OR 1 GW: WRITE DATA TO GRAPHIC PAGE 0 OR 1. (EFFECTIVE WHILE GP=1)	60 S	
DISPLAY SHIFT BY DOT	0	0	0	0	0	1	OA	LR	L1	L0	OA=1: ONE OF 4 LINES SHIFT ENABLE. OA=0: ALL LINE SHIFT ENABLE. LR=1: DOT BY DOT SHIFT RIGHT. LR=0: Dot by dot shift left. L1,L0: CHOICE ONE OF 4 LINES SHIFT	60 S	
FUNCTION SET (MODIFY)	0	0	0	0	1	CL	N	1	RE	G	GP	CL=1: SELECT 16 CHARACTER LINE CL=0: SELECT 8 CHARACTER LINE N=1 & RE=1: 4 LINE DISPLAY RE=1: EXTENDED INSTRUCTION SETTING. RE=0: NORMAL INSTRUCTION SETTING. G=1: GRAPHIC DISPLAY ON	60 S

												G=0: GRAPHIC DISPLAY OFF GP=1: TWO PAGE GRAM GP=0: ONE PAGE GRAM	
Set IRAM or Start Row ADDRESS	0	0	0	1	AC 5	AC 4	AC 3	AC 2	AC 1	AC 0		SR=1: AC5~AC0 IS START ROW SR=0: AC5~AC0 IS ICON RAM ADDRESS	60 S
SET GRAPHIC RAM ADDRESS	0	0	1	AC 6	AC 5	AC 4	AC 3	AC 2	AC 1	AC 0		SET GRAPHIC RAM ADDRESS IN ADDRESS COUNTER. EXECUTE ONCE SET THE ADDRESS OF DISPLAY ROW. EXECUTE AGAIN SET THE ADDRESS OF DISPLAY COLUMN. EACH ADDRESS OF DISPLAY COLUMN HAS DATA OF 16 BITS. THEREFORE WRITE DATA SHOULD EXECUTE 2 TIMES.	60 S

NOTE:

BE SURE THE ST7920 IS NOT IN THE BUSY STATE (BF = 0) BEFORE SENDING AN INSTRUCTION FROM THE MPU TO THE ST7920. IF AN INSTRUCTION IS SENT WITHOUT CHECKING THE BUSY FLAG, THE TIME BETWEEN THE FIRST INSTRUCTION AND NEXT INSTRUCTION WILL TAKE MUCH LONGER THAN THE INSTRUCTION TIME ITSELF. REFER TO INSTRUCTION TABLE FOR THE LIST OF EACH INSTRUCTION EXECUTION TIME.

10.1. Serial Interface & Transferring Serial Data

THE ST7920 ENTERS SERIAL MODE WHEN THE PSB PIN IS SET LOW. A TWO-LINE CLOCK SYNCHRONOUS TRANSFER METHOD IS USED. THE ST7920 RECEIVES SERIAL INPUT DATA(SID) BY SYNCHRONIZING WITH A TRANSFER CLOCK(SCLK) SENT FROM THE MASTER SIDE. WHEN THE ST7920 INTERFACES WITH SEVERAL CHIPS, CHIP SELECT PIN(CS) MUST BE USED. THE TRANSFER CLOCK(SCLK) INPUT IS ACTIVATED BY MAKING CHIP SELECT(CS) HIGH. IN ADDITION, THE TRANSFER COUNTER OF THE ST7920 CAN BE RESET AND SERIAL TRANSFER SYNCHRONIZED BY MAKING CHIP SELECT(CS) LOW. HERE, SINCE THE DATA WHICH WAS BEING SENT AT RESET IS CLEARED, RESTART THE TRANSFER FROM THE FIRST BIT OF THIS DATA. IN A MINIMUM SYSTEM WHERE A SINGLE ST7920 INTERFACES TO A SINGLE MPU, AN INTERFACE CAN BE CONSTRUCTED FROM THE TRANSFER CLOCK(SCLK) AND SERIAL INPUT DATA(SID). IN THIS CASE, CHIP SELECT(CS) SHOULD BE FIXED TO HIGH.

THE TRANSFER CLOCK(SCLK) IS INDEPENDENT OF OPERATIONAL CLOCK OF THE ST7920. HOWEVER, WHEN SEVERAL INSTRUCTIONS ARE CONTINUOUSLY TRANSFERRED, THE INSTRUCTION EXECUTION TIME DETERMINED BY THE OPERATIONAL CLOCK MUST BE CONSIDERED SINCE THE ST7920 DOES NOT HAVE AN INTERNAL TRANSMIT/RECEIVE BUFFER. FOLLOWING FIGURE SHOWS THE BASIC PROCEDURE FOR TRANSFERRING SERIAL DATA. TO BEGIN WITH, TRANSFER THE START BYTE. BY RECEIVING FIVE CONSECUTIVE BITS OF 1(SYNCHRONIZING BIT STRING) AT THE BEGINNING OF THE START BYTE, THE TRANSFER COUNTER OF THE ST7920 IS RESET AND SERIAL TRANSFER IS SYNCHRONIZED. THE 2 BITS FOLLOWING THE SYNCHRONIZING BIT STRING(5 BITS) SPECIFY TRANSFER DIRECTION(RW BIT) AND REGISTER SELECT(RS BIT). BE SURE TO TRANSFER 0 IN THE 8 TH BIT.

AFTER RECEIVING THE START SYNCHRONIZING BIT STRING, THE RW BIT(=0), AND RS BIT IN THE START BYTE, AN 8-BIT INSTRUCTION IS RECEIVED IN 2 BYTES: THE HIGHER 4 BITS OF THE INSTRUCTION ARE PLACED IN THE LSB OF THE FIRST BYTE, AND THE LOWER 4 BITS OF THE INSTRUCTION ARE PLACED IN THE LSB OF THE SECOND BYTE. BE SURE TO TRANSFER 0 IN THE FOLLOWING 4 BITS OF EACH BYTE.

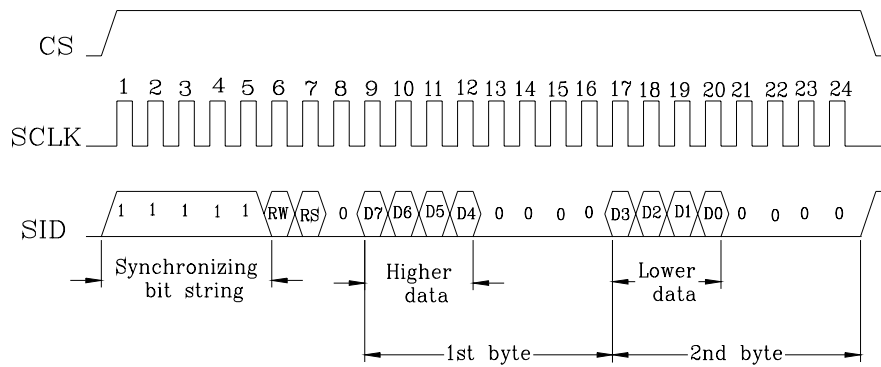

11. INITIALIZING BY INSTRUCTION

- 8-BIT INTERFACE:

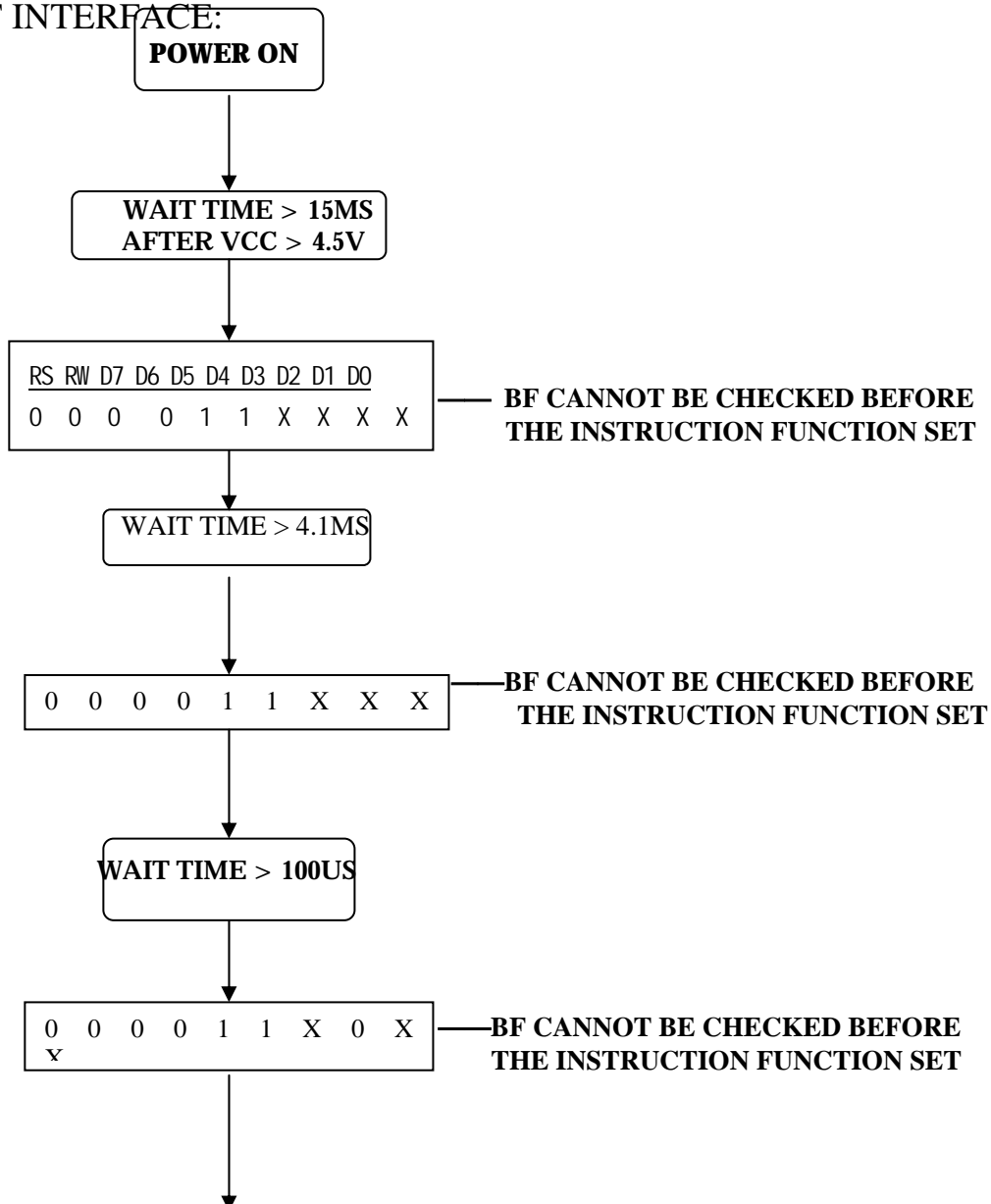

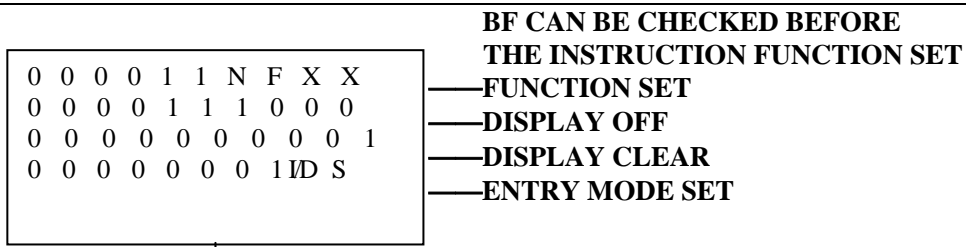

INITIALIZATION END

● **4-BIT INTERFACE POWER ON**

WAIT TIME > 15MS
AFTER VCC > 4.5V

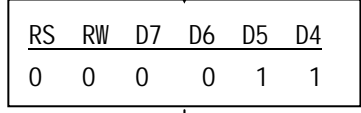

— **BF CANNOT BE CHECKED BEFORE THE INSTRUCTION FUNCTION SET**

WAIT TIME > 4.1MS

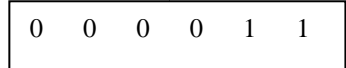

— **BF CANNOT BE CHECKED BEFORE THE INSTRUCTION FUNCTION SET**

WAIT TIME > 100US

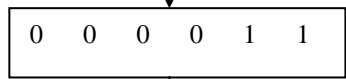

— **BF CANNOT BE CHECKED BEFORE THE INSTRUCTION FUNCTION SET**

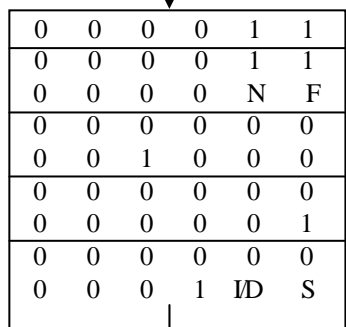

— **BF CAN BE CHECKED BEFORE THE INSTRUCTION FUNCTION SET**

— **FUNCTION SET**

— **DISPLAY OFF**

— **DISPLAY CLEAR**

— **ENTRY MODE SET**

INITIALIZATION END

1. ST7920 BIG-5 中文字型码表

A140	· · · · · · ; : ? ! : · · · · · , \ .
A150	· ; : ? ! - - _ { ~ () ^
A160	~ { } ~ ~ [] ~ ~ 【 】 ~ ~ 《 》 ^
A170	≡ < > ^ v 「 」 ~ ~ 『 』 ~ ~ ()
A1A0	{ } [] ' ' " " ~ ~ # & *
A1B0	※ § " ○ ● △ ▲ ◎ ☆ ★ ◇ ◆ □ ■ ▽ ▼
A1C0	Ⓢ % - _ ~ ~ ~ ~ ~ ~ ~ ~ # & * +
A1D0	-x ÷ ± √ < > = ≤ ≥ ≠ ∞ ≈ ≡ + -
A1E0	< > = ~ ∩ ∪ ⊥ ∠ ∟ log ln § \$ ∴ ∴
A1F0	♀ ♂ ⊕ ⊙ ↑ ↓ ↔ ↗ ↘ ↙ ↘ /
A240	\ / \\$ ¥ ¤ ¤ £ % @ ° C ° F \$ % @ mil
A250	mm cm km KM m ² mg kg cc ° 尪 尪 尪 尪 尪 尪
A260	尪 尪 尪 尪 尪 尪 尪 尪 尪 尪 尪 尪 尪 尪
A270	尪 尪 尪 尪 尪 尪 尪 尪 尪 尪 尪 尪 尪 尪
A2A0	ㄿ ㄿ ㄿ = ㄿ ㄿ ㄿ ▲ ▲ ▼ ▼ / \ × 0
A2B0	1 2 3 4 5 6 7 8 9 I II III IV V VI VII
A2C0	VIII IX X ㄨ ㄨ ㄨ ㄨ 文 十 卅 卅 A
A2D0	B C D E F G H I J K L M N O P Q
A2E0	R S T U V W X Y Z A B C D E F G
A2F0	H I J K L M N O P Q R S T U V
A340	W X Y Z A B Γ Δ E Z H Θ I K Λ M
A350	N Ξ O Π P Σ T Υ Φ X Ψ Ω A B Γ Δ
A360	E Z H Θ I K Λ M N Ξ O Π P Σ T Υ
A370	Φ X Ψ Ω ㄣ ㄣ ㄣ ㄣ ㄣ ㄣ ㄣ ㄣ ㄣ ㄣ
A3A0	ㄣ ㄣ ㄣ ㄣ ㄣ ㄣ ㄣ ㄣ ㄣ ㄣ ㄣ ㄣ ㄣ
A3B0	ㄣ ㄣ ㄣ ㄣ ㄣ ㄣ ㄣ ㄣ ㄣ ㄣ ㄣ ㄣ ㄣ
F9E0	ㄣ ㄣ ㄣ ㄣ ㄣ ㄣ ㄣ ㄣ ㄣ ㄣ ㄣ ㄣ ㄣ
F9F0	ㄣ ㄣ ㄣ ㄣ ㄣ ㄣ ㄣ ㄣ ㄣ ㄣ ㄣ ㄣ ㄣ

12.1 Specification of quality assurance

AQL inspection standard

Sampling method: MIL-STD-105E, Level II, single sampling

Defect classification **(Note: * is not including)**

Classify	Item		Note	AQL
Major	Display state	Short or open circuit	1	0.65
		LC leakage		
		Flickering		
		No display		
		Wrong viewing direction		
		Contrast defect (dim, ghost)	2	
		Back-light	1,8	
	Non-display	Flat cable or pin reverse	10	
		Wrong or missing component	11	
Minor	Display state	Background color deviation	2	1.0
		Black spot and dust	3	
		Line defect, Scratch	4	
		Rainbow	5	
		Chip	6	
		Pin hole	7	
	Polarizer	Protruded	12	
		Bubble and foreign material	3	
	Soldering	Poor connection	9	
	Wire	Poor connection	10	
	TAB	Position, Bonding strength	13	

Note on defect classification

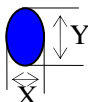
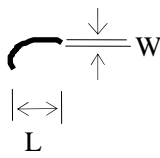
No.	Item	Criterion																				
1	Short or open circuit	Not allow																				
	LC leakage																					
	Flickering																					
	No display																					
	Wrong viewing direction																					
	Wrong Back-light																					
2	Contrast defect	Refer to approval sample																				
	Background color deviation																					
3	Point defect, Black spot, dust (including Polarizer) $\phi = (X+Y)/2$	 <table border="1" data-bbox="861 862 1300 1164"> <thead> <tr> <th>Point Size</th> <th>Acceptable Qty.</th> </tr> </thead> <tbody> <tr> <td>$\phi \leq 0.10$</td> <td>Disregard</td> </tr> <tr> <td>$0.10 < \phi \leq 0.20$</td> <td>3</td> </tr> <tr> <td>$0.20 < \phi \leq 0.25$</td> <td>2</td> </tr> <tr> <td>$0.25 < \phi \leq 0.30$</td> <td>1</td> </tr> <tr> <td>$\phi > 0.30$</td> <td>0</td> </tr> </tbody> </table> <p style="text-align: right;">Unit : mm</p>	Point Size	Acceptable Qty.	$\phi \leq 0.10$	Disregard	$0.10 < \phi \leq 0.20$	3	$0.20 < \phi \leq 0.25$	2	$0.25 < \phi \leq 0.30$	1	$\phi > 0.30$	0								
Point Size	Acceptable Qty.																					
$\phi \leq 0.10$	Disregard																					
$0.10 < \phi \leq 0.20$	3																					
$0.20 < \phi \leq 0.25$	2																					
$0.25 < \phi \leq 0.30$	1																					
$\phi > 0.30$	0																					
4	Line defect, Scratch	 <table border="1" data-bbox="790 1288 1340 1556"> <thead> <tr> <th colspan="2">Line</th> <th>Acceptable Qty.</th> </tr> <tr> <th>L</th> <th>W</th> <th></th> </tr> </thead> <tbody> <tr> <td>---</td> <td>$0.015 \leq W$</td> <td>Disregard</td> </tr> <tr> <td>3.0 L</td> <td>$0.03 \leq W$</td> <td rowspan="2">2</td> </tr> <tr> <td>2.0 L</td> <td>$0.05 \leq W$</td> </tr> <tr> <td>1.0 L</td> <td>$0.1 > W$</td> <td>1</td> </tr> <tr> <td>---</td> <td>$0.05 < W$</td> <td>Applied as point defect</td> </tr> </tbody> </table> <p style="text-align: right;">Unit: mm</p>	Line		Acceptable Qty.	L	W		---	$0.015 \leq W$	Disregard	3.0 L	$0.03 \leq W$	2	2.0 L	$0.05 \leq W$	1.0 L	$0.1 > W$	1	---	$0.05 < W$	Applied as point defect
Line		Acceptable Qty.																				
L	W																					
---	$0.015 \leq W$	Disregard																				
3.0 L	$0.03 \leq W$	2																				
2.0 L	$0.05 \leq W$																					
1.0 L	$0.1 > W$	1																				
---	$0.05 < W$	Applied as point defect																				
5	Rainbow	Not more than two color changes across the viewing area.																				

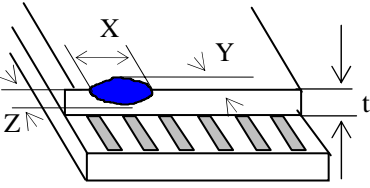
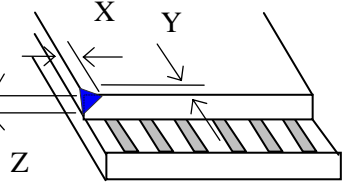
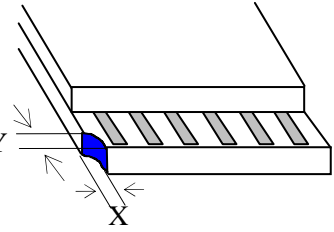
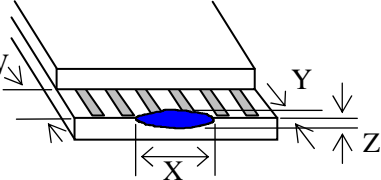
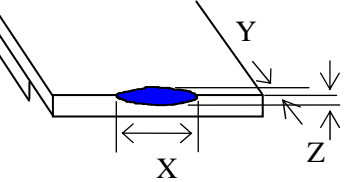
No	Item	Criterion																																	
6	<p>Chip</p> <p>Remark:</p> <p>X: Length direction</p> <p>Y: Short direction</p> <p>Z: Thickness direction</p> <p>t: Glass thickness</p> <p>W: Terminal Width</p>	 <p>Acceptable criterion</p> <table border="1" data-bbox="938 353 1326 434"> <thead> <tr> <th>X</th> <th>Y</th> <th>Z</th> </tr> </thead> <tbody> <tr> <td>2</td> <td>0.5mm</td> <td>t/2</td> </tr> </tbody> </table>  <p>Acceptable criterion</p> <table border="1" data-bbox="927 667 1329 748"> <thead> <tr> <th>X</th> <th>Y</th> <th>Z</th> </tr> </thead> <tbody> <tr> <td>2</td> <td>0.5mm</td> <td>t</td> </tr> </tbody> </table>  <p>Acceptable criterion</p> <table border="1" data-bbox="943 958 1329 1070"> <thead> <tr> <th>X</th> <th>Y</th> <th>Z</th> </tr> </thead> <tbody> <tr> <td>3</td> <td>2</td> <td>t</td> </tr> <tr> <td colspan="2">shall not reach to ITO</td> <td></td> </tr> </tbody> </table>  <p>Acceptable criterion</p> <table border="1" data-bbox="927 1339 1329 1420"> <thead> <tr> <th>X</th> <th>Y</th> <th>Z</th> </tr> </thead> <tbody> <tr> <td>Disregard</td> <td>0.2</td> <td>t</td> </tr> </tbody> </table>  <p>Acceptable criterion</p> <table border="1" data-bbox="927 1621 1297 1702"> <thead> <tr> <th>X</th> <th>Y</th> <th>Z</th> </tr> </thead> <tbody> <tr> <td>5</td> <td>2</td> <td>t/3</td> </tr> </tbody> </table>	X	Y	Z	2	0.5mm	t/2	X	Y	Z	2	0.5mm	t	X	Y	Z	3	2	t	shall not reach to ITO			X	Y	Z	Disregard	0.2	t	X	Y	Z	5	2	t/3
X	Y	Z																																	
2	0.5mm	t/2																																	
X	Y	Z																																	
2	0.5mm	t																																	
X	Y	Z																																	
3	2	t																																	
shall not reach to ITO																																			
X	Y	Z																																	
Disregard	0.2	t																																	
X	Y	Z																																	
5	2	t/3																																	

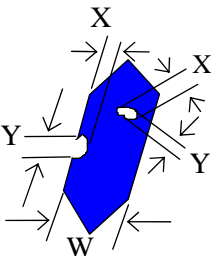
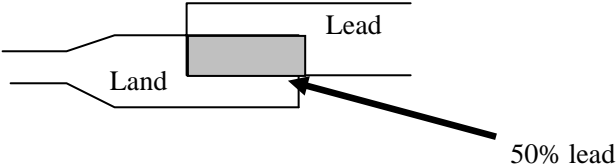
No.	Item	Criterion								
7	Segment pattern $W = \text{Segment width}$ $\phi = (X+Y)/2$	(1) Pin hole $\phi < 0.10\text{mm}$ is acceptable.  <table border="1" data-bbox="855 528 1316 698"> <thead> <tr> <th>Point Size</th> <th>Acceptable Qty</th> </tr> </thead> <tbody> <tr> <td>$\phi < 1/4W$</td> <td>Disregard</td> </tr> <tr> <td>$1/4W < \phi < 1/2W$</td> <td>1</td> </tr> <tr> <td>$\phi > 1/2W$</td> <td>0</td> </tr> </tbody> </table> <p style="text-align: right;">Unit: mm</p>	Point Size	Acceptable Qty	$\phi < 1/4W$	Disregard	$1/4W < \phi < 1/2W$	1	$\phi > 1/2W$	0
Point Size	Acceptable Qty									
$\phi < 1/4W$	Disregard									
$1/4W < \phi < 1/2W$	1									
$\phi > 1/2W$	0									
8	Back-light	(1) The color of backlight should correspond its specification. (2) Not allow flickering								
9	Soldering	(1) Not allow heavy dirty and solder ball on PCB. (The size of dirty refer to point and dust defect) (2) Over 50% of lead should be soldered on Land. 								
10	Wire	(1) Copper wire should not be rusted (2) Not allow crack on copper wire connection. (3) Not allow reversing the position of the flat cable. (4) Not allow exposed copper wire inside the flat cable.								
11*	PCB	(1) Not allow screw rust or damage. (2) Not allow missing or wrong putting of component.								

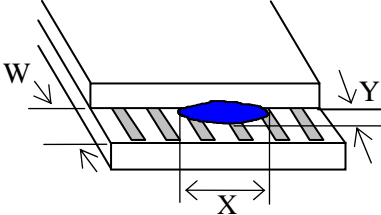
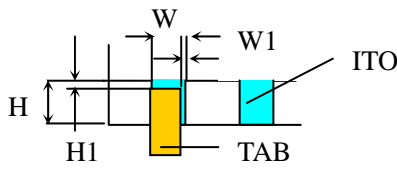
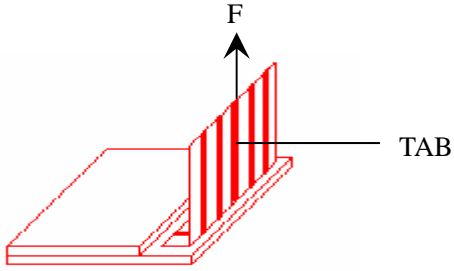
No	Item	Criterion				
12	Protruded W: Terminal Width	 <p>Acceptable criteria: $Y \leq 0.4$</p>				
13	TAB	<p>1. Position</p>  <table border="1" data-bbox="1117 716 1348 851"> <tr> <td>W1</td> <td>1/3W</td> </tr> <tr> <td>H1</td> <td>1/3H</td> </tr> </table> <p>2. TAB bonding strength test</p>  <p> $P (=F/\text{TAB bonding width})$ 650gf/cm ,(speed rate: 1mm/min) 5pcs per SOA (shipment) </p>	W1	1/3W	H1	1/3H
W1	1/3W					
H1	1/3H					
14	Total no. of acceptable Defect	<p>A. Zone</p> <p>Maximum 2 minor non-conformities per one unit.</p> <p>Defect distance: each point to be separated over 10mm</p> <p>B. Zone</p> <p>It is acceptable when it is no trouble for quality and assembly in customer's end product.</p>				

12.2 Reliability of LCM

Reliability test condition:

Item	Condition	Time (hrs)	Assessment
High temp. Storage	80°C	48	No abnormalities in functions and appearance
High temp. Operating	70°C	48	
Low temp. Storage	-30°C	48	
Low temp. Operating	-20°C	48	
Humidity	40°C/ 90%RH	48	
Temp. Cycle	0°C ← 25°C → 50°C (30 min ← 5 min → 30min)	10cycles	

Recovery time should be 24 hours minimum. Moreover, functions, performance and appearance shall be free from remarkable deterioration within 50,000 hours under ordinary operating and storage conditions room temperature (20±8°C), normal humidity (below 65% RH), and in the area not exposed to direct sun light.

12.3 Precaution for using LCD/LCM

LCD/LCM is assembled and adjusted with a high degree of precision. Do not attempt to make any alteration or modification. The followings should be noted.

General Precautions:

1. LCD panel is made of glass. Avoid excessive mechanical shock or applying strong pressure onto the surface of display area.
2. The polarizer used on the display surface is easily scratched and damaged. Extreme care should be taken when handling. To clean dust or dirt off the display surface, wipe gently with cotton, or other soft material soaked with isopropyl alcohol, ethyl alcohol or trichlorotrifluoroethane, do not use water, ketone or aromatics and never scrub hard.
3. Do not tamper in any way with the tabs on the metal frame.
4. Do not make any modification on the PCB without consulting Newhaven Display
5. When mounting a LCM, make sure that the PCB is not under any stress such as bending or twisting. Elastomer contacts are very delicate and missing pixels could result from slight dislocation of any of the elements.
6. Avoid pressing on the metal bezel, otherwise the elastomer connector could be deformed and lose contact, resulting in missing pixels and also cause rainbow on the display.
7. Be careful not to touch or swallow liquid crystal that might leak from a damaged cell. Any liquid crystal adheres to skin or clothes, wash it off immediately with soap and water.

Static Electricity Precautions:

1. CMOS-LSI is used for the module circuit; therefore operators should be grounded whenever he/she comes into contact with the module.
2. Do not touch any of the conductive parts such as the LSI pads; the copper leads on the PCB and

-
- the interface terminals with any parts of the human body.
3. Do not touch the connection terminals of the display with bare hand; it will cause disconnection or defective insulation of terminals.
 4. The modules should be kept in anti-static bags or other containers resistant to static for storage.
 5. Only properly grounded soldering irons should be used.
 6. If an electric screwdriver is used, it should be grounded and shielded to prevent sparks.
 7. The normal static prevention measures should be observed for work clothes and working benches.
 8. Since dry air is inductive to static, a relative humidity of 50-60% is recommended.

Soldering Precautions:

1. Soldering should be performed only on the I/O terminals.
2. Use soldering irons with proper grounding and no leakage.
3. Soldering temperature: $280^{\circ}\text{C}\pm 10^{\circ}\text{C}$
4. Soldering time: 3 to 4 second.
5. Use eutectic solder with resin flux filling.
6. If flux is used, the LCD surface should be protected to avoid spattering flux.
7. Flux residue should be removed.

Operation Precautions:

1. The viewing angle can be adjusted by varying the LCD driving voltage V_o .
2. Since applied DC voltage causes electro-chemical reactions, which deteriorate the display, the applied pulse waveform should be a symmetric waveform such that no DC component remains. Be sure to use the specified operating voltage.
3. Driving voltage should be kept within specified range; excess voltage will shorten display life.
4. Response time increases with decrease in temperature.
5. Display color may be affected at temperatures above its operational range.
6. Keep the temperature within the specified range usage and storage. Excessive temperature and humidity could cause polarization degradation, polarizer peel-off or generate bubbles.
7. For long-term storage over 40°C is required, the relative humidity should be kept below 60%, and avoid direct sunlight.

Limited Warranty

Newhaven Display LCDs and modules are not consumer products, but may be incorporated by Newhaven Display's customers into consumer products or components thereof, Newhaven Display does not warrant that its LCDs and components are fit for any such particular purpose.

1. The liability of Newhaven Display is limited to repair or replacement on the terms set forth below. Newhaven Display will not be responsible for any subsequent or consequential events or injury or damage to any personnel or user including third party personnel and/or user. Unless otherwise agreed in writing between Newhaven Display and the customer, Newhaven Display will only replace or repair any of its LCD which is found defective electrically or visually when inspected in accordance with Newhaven Display general LCD inspection standard .
(Copies available on request)
2. No warranty can be granted if any of the precautions state in handling liquid crystal display above has been disregarded. Broken glass, scratches on polarizer mechanical damages as well as defects that are caused accelerated environment tests are excluded from warranty.
3. In returning the LCD/LCM, they must be properly packaged; there should be detailed description of the failures or defect.